

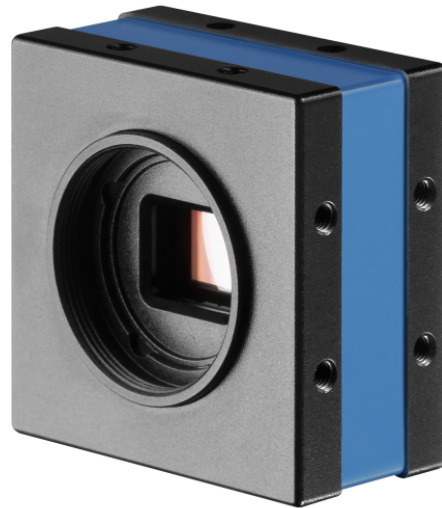

Technical Details



# DMK 37AUX252 Technical Reference Manual



<b>1. Quick Facts</b>	<b>4</b>
<b>2. Dimensional Diagrams</b>	<b>6</b>
2.1 DMK 37AUX252 C-Mount with Tripod Adapter .....	6
2.2 DMK 37AUX252 C-Mount without Tripod Adapter .....	7
2.3 DMK 37AUX252 CS-Mount with Tripod Adapter .....	8
2.4 DMK 37AUX252 CS-Mount without Tripod Adapter .....	9
<b>3. Spectral Characteristics</b>	<b>10</b>
3.1 Spectral Sensitivity - IMX252LLR-C .....	10
<b>4. Camera Controls</b>	<b>11</b>
<b>4.1 Sensor Readout Control</b> .....	<b>11</b>
4.1.1 Pixel Format .....	11
4.1.1.1 8-Bit Monochrome .....	11
4.1.1.2 16-Bit Monochrome .....	12
4.1.2 Resolution .....	12
4.1.3 Readout Modes .....	13
4.1.4 Frame Rate .....	14
4.1.5 Partial Scan Offset .....	15
4.1.6 Image Flipping .....	17
<b>4.2 Image Sensor Control</b> .....	<b>17</b>
4.2.1 Exposure Time .....	17
4.2.2 Gain .....	18
4.2.3 Black Level .....	18
<b>4.3 Automatic Exposure and Gain Control</b> .....	<b>18</b>
4.3.1 Auto Exposure .....	19
4.3.2 Auto Gain .....	19
4.3.3 Auto Reference Value .....	19
4.3.4 Highlight Reduction .....	20
4.3.5 Auto Exposure Limits .....	20
4.3.6 Auto Gain Limits .....	21
<b>4.4 Trigger</b> .....	<b>22</b>
4.4.1 Trigger Mode .....	22
4.4.2 Trigger Polarity .....	22
4.4.3 Software Trigger .....	23
4.4.4 Trigger Exposure Mode .....	23
4.4.5 IMX Low-Latency Mode .....	24
4.4.6 Trigger Overlap .....	24
4.4.7 Trigger Delay .....	25
<b>4.5 Digital I/O</b> .....	<b>25</b>
4.5.1 General Purpose Input .....	25
4.5.2 General Purpose Output .....	26



<b>4.6</b>	<b>Strobe</b> .....	<b>26</b>
4.6.1	Strobe Enable .....	26
4.6.2	Strobe Polarity .....	27
4.6.3	Strobe Operation .....	27
4.6.4	Strobe Duration .....	28
4.6.5	Strobe Delay .....	28
<b>4.7</b>	<b>Region of Interest for Auto Functions</b> .....	<b>29</b>
4.7.1	Auto Functions ROI Enable .....	29
4.7.2	Auto Functions ROI Preset .....	29
<b>4.8</b>	<b>User Sets</b> .....	<b>29</b>
4.8.1	User Set Selector .....	29
4.8.2	Load User Set .....	30
4.8.3	Save User Set .....	30
4.8.4	Default User Set .....	30
<b>4.9</b>	<b>Multi-Frame Output Mode</b> .....	<b>31</b>
4.9.1	Multi-Frame Output Mode Enable .....	31
4.9.2	Multi-Frame Output Mode Frame Count .....	31
4.9.3	Multi-Frame Output Mode Exposure Time .....	32
4.9.4	Multi-Frame Output Mode Custom Gain .....	32
4.9.5	Multi-Frame Output Mode Gain .....	33
<b>4.10</b>	<b>Timestamp Control</b> .....	<b>33</b>
4.10.1	Timestamp Latch .....	33
4.10.2	Timestamp Latch Value .....	33
4.10.3	Timestamp Reset .....	34
<b>4.11</b>	<b>Bandwidth Control</b> .....	<b>34</b>
4.11.1	Device Link Throughput Limit Mode .....	34
4.11.2	Device Link Throughput Limit .....	34
<b>5.</b>	<b>Revision History</b>	<b>36</b>



## 1 Quick Facts

<b>General</b>	
Vision Standard	USB3 Vision
Dynamic Range	12 bit
Resolution	2048x1536
Frame Rate at Full Resolution	119
Pixel Formats	8-Bit Monochrome 16-Bit Monochrome

<b>Optical Interface</b>	
IR-Cut filter	No
Sensor Type	Sony IMX252LLR-C
Shutter Type	Global
Sensor Format	1/1.8 inch
Pixel Size	3.45 $\mu\text{m}$
Lens Mount	C/CS

<b>Electrical Interface</b>	
Interface	USB 3.1gen1
Supply Voltage	4.75 VDC to 5.25 VDC
Current Consumption	approx 420 mA @ 5 VDC

<b>Mechanical Data</b>	
Dimensions	H: 42 mm, W: 42 mm, L: 25 mm
Mass	76 g

<b>Adjustments</b>	
Shutter	1 $\mu\text{s}$ to 4 s
Gain	0 dB to 48 dB



<b>Environmental Conditions</b>	
Housing Temperature (operating)	-5 °C to 50 °C
Temperature (storage)	-20 °C to 80 °C
Humidity (operating)	20 % to 80 % (non-condensing)
Humidity (storage)	20 % to 95 % (non-condensing)



## 2 Dimensional Diagrams

### 2.1 DMK 37AUX252 C-Mount with Tripod Adapter

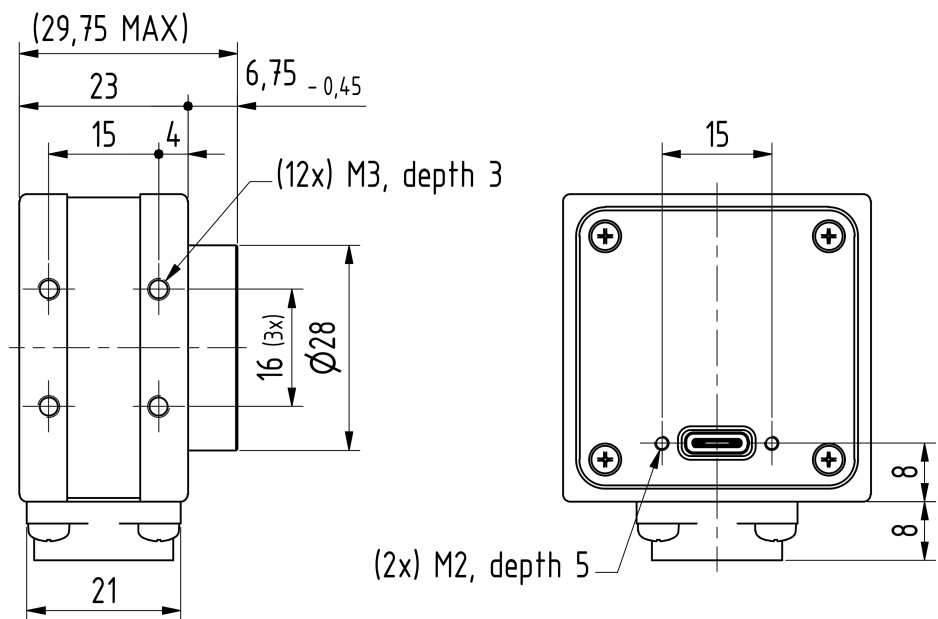
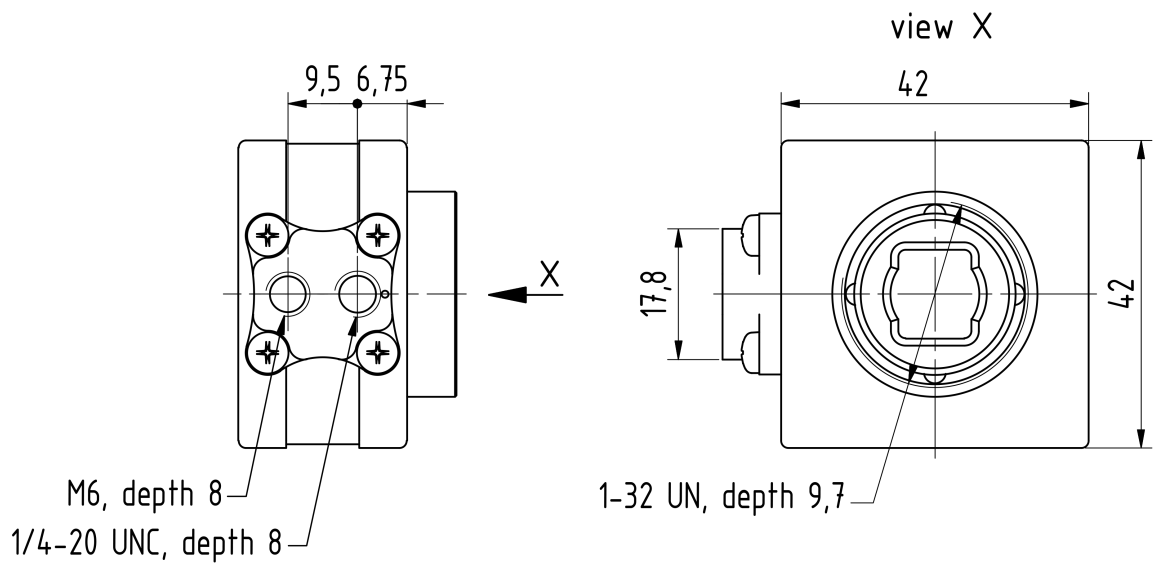

Dimensions: mm  
Tolerances: DIN ISO 2768-f

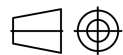



## 2.2 DMK 37AUX252 C-Mount without Tripod Adapter

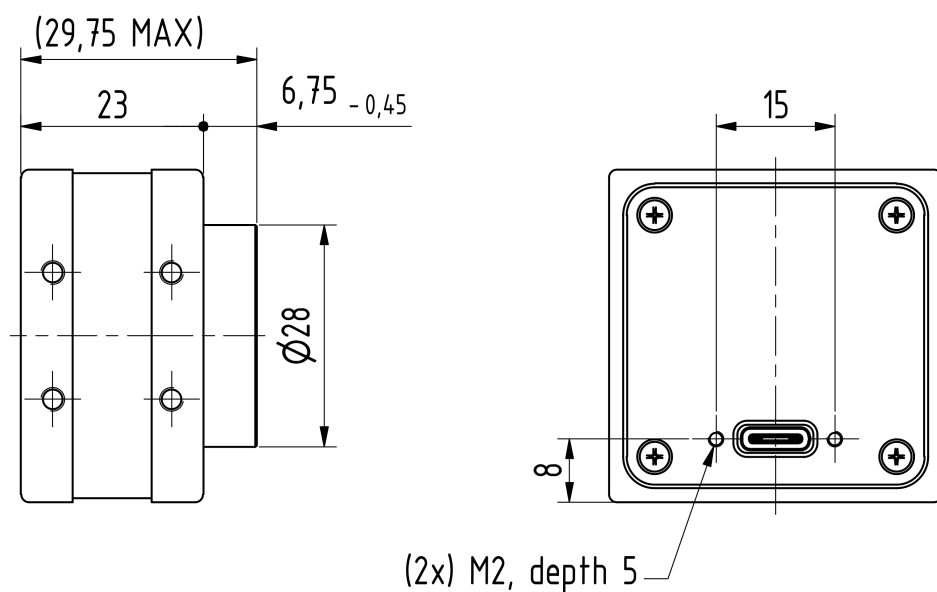
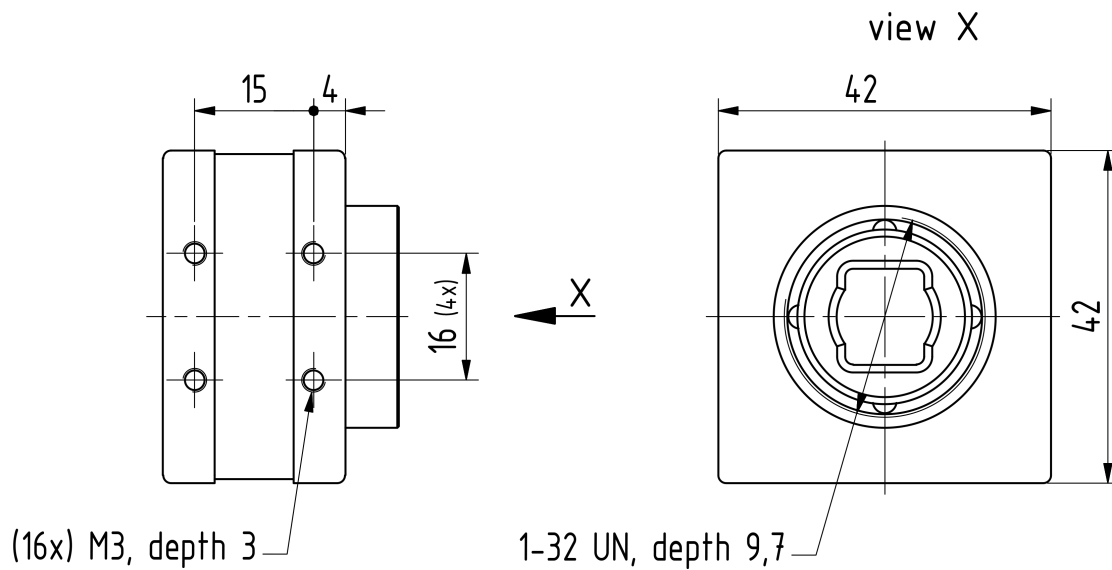

Dimensions: mm  
Tolerances: DIN ISO 2768-f





## 2.3 DMK 37AUX252 CS-Mount with Tripod Adapter

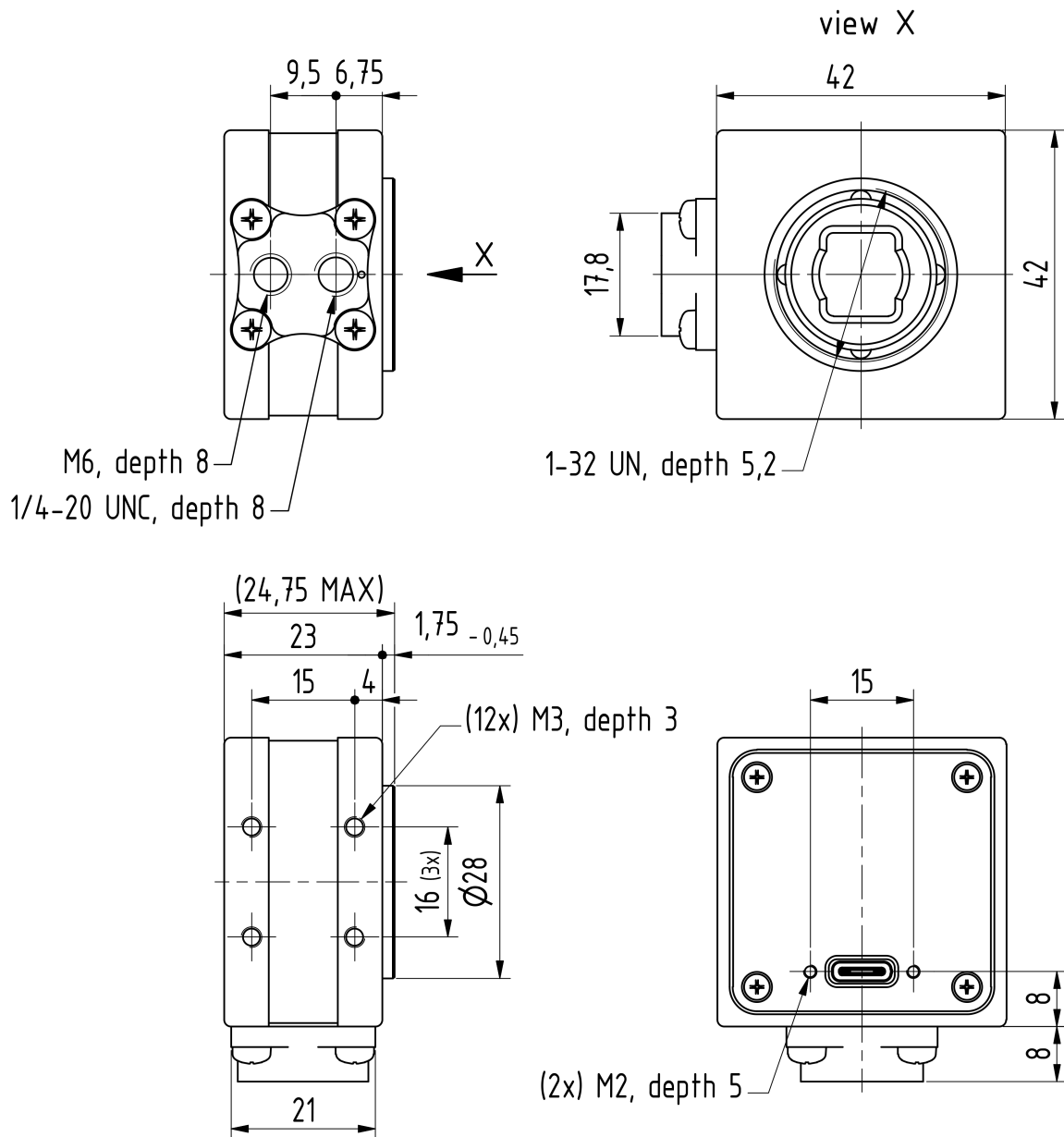

Dimensions: mm  
Tolerances: DIN ISO 2768-f







## 2.4 DMK 37AUX252 CS-Mount without Tripod Adapter

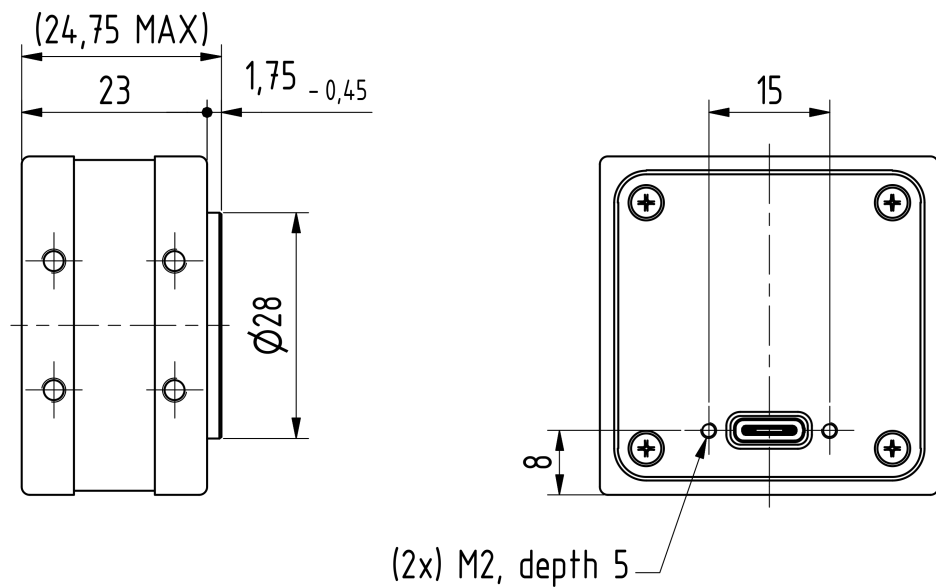
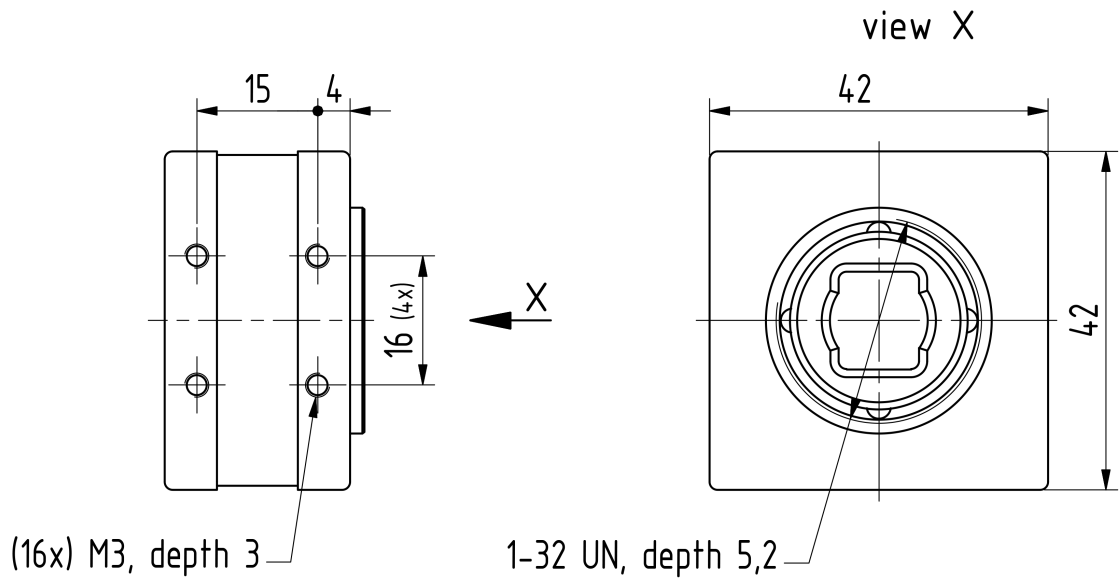

Dimensions: mm  
Tolerances: DIN ISO 2768-f

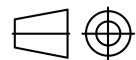



## 3 Spectral Characteristics

### 3.1 Spectral Sensitivity - IMX252LLR-C

Sensor: Sony IMX250/252/264/265 - courtesy of Sony Deutschland GmbH

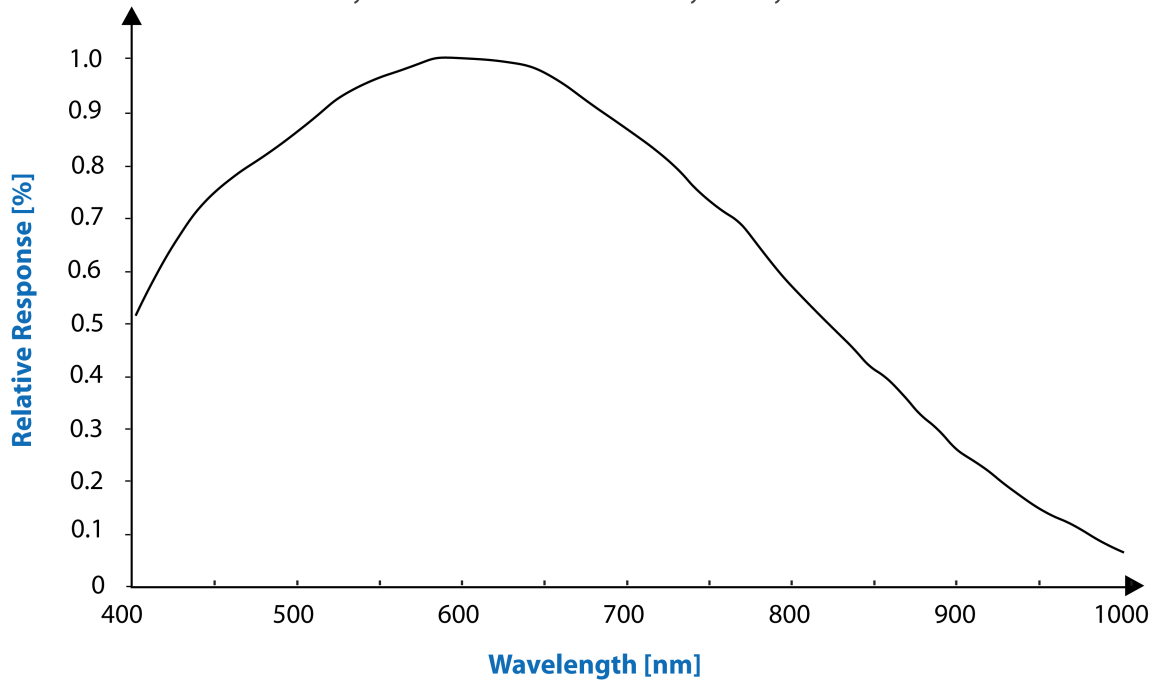



## 4 Camera Controls

This section describes the parameters available for the DMK 37AUX252 camera.

The actual name of the parameter depends on the driver technology used to access the camera. Parameter names are listed for the most common ways to access the cameras:

- *USB3 Vision (IC Imaging Control 4, or via 3rd party driver)*
- *UVC/V4L2 (on Linux, via uvcvideo)*
- *IC Imaging Control 3.x (on Windows, via Device Driver for The Imaging Source USB 33U, 37U and 38U Cameras)*

Please note: When the camera is connected to a USB2 controller and used in V4L2 mode or by *IC Imaging Control 3.x*, read requests can lead to frame drops. Avoid reading camera features to ensure a stable image transmission.

### 4.1 Sensor Readout Control

#### 4.1.1 Pixel Format

The pixel format defines the data type of the pixels transmitted to the computer. The bits per pixel needed for a particular pixel format influence the required bandwidth.

The way the pixel format is controlled varies significantly among the driver technology used to access the camera:

- When using *IC Imaging Control 4* or *USB3 Vision*, the pixel format is controlled through the `PixelFormat GenICam` feature.
- When using the *uvcvideo* driver on Linux, the pixel format is defined by `video4linux2`.
- When using *IC Imaging Control 3.x*, the pixel format is part of the video format - a parameter which combines pixel format, resolution and readout mode. For more information, refer to the *IC Imaging Control 3.x* documentation sections on `VideoFormat` and `VideoFormatDesc`.

The DMK 37AUX252 monochrome camera supports multiple pixel formats with variable bits-per-pixel settings. The names of the pixel formats and the way to select them depends on the driver used to control the camera. The following table contains a short overview of all possible formats followed by a more detailed description.

Pixel Format	Bits Per Pixel	USB3 Vision	UVC	TIS UVC Driver
8-Bit Monochrome	8	Mon08	Y800	Y800
16-Bit Packed Monochrome	16	Mon16	Y16	Y16

##### 4.1.1.1 8-Bit Monochrome

This format transmits data using one byte for each pixel.

*USB3 Vision* drivers see this pixel format as `Mon08`.



UVC drivers see it with the *FourCC* `Y800`.

The *Device Driver for The Imaging Source USB 33U, 37U and 38U Cameras* offers this pixel format as the `Y800` video format.

#### 4.1.1.2 16-Bit Monochrome

The sensor of the DMK 37AUX252 camera is not capable of providing 16-bit data output. Instead, the pixel data is transmitted in the most significant bits which allows application programs to ignore the sensor-specific data type, and treat the data as if the sensor outputs 16 bits.

*USB3 Vision* drivers see this pixel format as `Mono16`.

UVC drivers see it with the *FourCC* `Y16`.

The *Device Driver for The Imaging Source USB 33U, 37U and 38U Cameras* offers this pixel format as the `Y16` video format.

#### 4.1.2 Resolution

The DMK 37AUX252 allows the user to specify which rectangular region of the image sensor to read out during camera operation. The size of this rectangle determines the number of pixels that have to be transferred for each frame and has a significant influence on the required USB bandwidth.

Lowering the resolution also often allows the image sensor to operate at a higher frame rate. Changes in the vertical resolution have more effect on the maximum frame rate than changes in the horizontal direction.

The way the resolution is controlled varies greatly between the driver technology used to access the camera:

- When using *USB3 Vision*, the resolution is controlled through the GenICam features `Width` and `Height`.
- When using the `uvcdm` on Linux, the resolution is selected from a list of fixed formats. Dynamic frame sizes are not available.
- When using *IC Imaging Control*, the resolution is part of the video format, a parameter that combines pixel format, resolution and readout mode. For more information, refer to the *IC Imaging Control* documentation sections on `VideoFormat` and `VideoFormatDesc`.

Parameter	Horizontal Resolution
Minimum	256
Maximum	2048
Increment	16
USB3 Vision: GenICam	<code>Width</code>
Type	Integer



Parameter	Vertical Resolution
Minimum	4
Maximum	1536
Increment	2
USB3 Vision: GenICam	Height
Type	Integer

### 4.1.3 Readout Modes

The DMK 37AUX252 camera offers different sensor readout modes.

By default, the camera outputs all pixels of the image sensor.

In *skipping* modes, the image sensor regularly skips a number of rows and/or columns during readout. The resulting output image is smaller but contains the same field of view than the image produced by default readout mode.

In *binning* modes, a number of neighboring pixels is merged into one output pixel during readout. The nature of this merge operation is sensor-specific, most sensors either add the pixel values or average them.

Generally, binning modes provide better image quality than skipping modes. However, skipping modes usually provide a higher maximum frame rate.

The way the readout modes are controlled depends greatly upon which driver technology is used to access the camera:

- When using *USB3 Vision*, the readout mode is controlled through the *GenICam* features `DecimationHorizontal`, `DecimationVertical`, `BinningHorizontal` and `BinningVertical`.
- When using *IC Imaging Control*, the readout mode is part of the video format - a parameter that which combines pixel format, resolution and readout mode. For more information, refer to the *IC Imaging Control* documentation sections on `VideoFormat` and `VideoFormatDesc`.

The following readout modes are supported:

- Default
- Skipping 2X
- Skipping 2X vertical
- Skipping 2X horizontal
- Binning 2X



Parameter	Binning Horizontal
Valid Values	1, 2
USB3 Vision: GenICam	BinningHorizontal
Type	Integer

Parameter	Binning Vertical
Valid Values	1, 2
USB3 Vision: GenICam	BinningVertical
Type	Integer

Parameter	Skipping Horizontal
Valid Values	1, 2
USB3 Vision: GenICam	DecimationHorizontal
Type	Integer

Parameter	Skipping Vertical
Valid Values	1, 2
USB3 Vision: GenICam	DecimationVertical
Type	Integer

#### 4.1.4 Frame Rate

The frame rate is specified in frames per second and determines the camera's operating speed.

The way the frame rate is controlled depends greatly upon which driver technology is used to access the camera:

- When using *USB3 Vision*, the frame rate is controlled through the *GenICam* feature `AcquisitionFrameRate`.
- When using `uvccv2` on Linux, the frame rate is selected from a list of available frame rates.
- When using IC Imaging Control, the frame rate is selected from a list of available frame rates through APIs such as `Grabber::setFPS` or `ICImagingControl.DeviceFrameRate`.

The range of available frame rates depends upon other camera settings such as well, pixel format, resolution and readout modes.



Parameter	Frame Rate
Minimum	Depending on Pixel Format, Resolution, and Readout Mode
Maximum	Depending on Pixel Format, Resolution, and Readout Mode
USB3 Vision: GenICam	AcquisitionFrameRate
Type	Float

**Please note:** Enabling [Device Link Throughput Limit Mode](#) can limit the frame rate below the configured value.

The following tables show the maximum frame rate for some combinations of pixel format and resolution.

### 8-Bit Monochrome

Width	Height	Maximum Frame Rate
2048	1536	119
1920	1080	172
640	480	371

### 16-Bit Monochrome

Width	Height	Maximum Frame Rate
2048	1536	60
1920	1080	91
640	480	371

#### 4.1.5 Partial Scan Offset

If the selected resolution is smaller than the sensor size, the part of the sensor that is actually read out can be specified by the *Partial Scan Offset X* and *Partial Scan Offset Y* parameters. By default, the camera automatically positions the offsets so that the center of the sensor is used.



Parameter	Partial Scan Offset X
Minimum	0
Maximum	1792
Increment	2
USB3 Vision: GenICam	OffsetX
Type	Integer
Video4Linux2	ROI Offset X
VCD Property	VCDID_PartialScanOffset \VCDElement_PartialScanOffsetX

Parameter	Partial Scan Offset Y
Minimum	0
Maximum	1532
Increment	2
USB3 Vision: GenICam	OffsetY
Type	Integer
Video4Linux2	ROI Offset Y
VCD Property	VCDID_PartialScanOffset \VCDElement_PartialScanOffsetY

If *Partial Scan Offset X* or *Partial Scan Offset Y* is configured to a value that would be invalid with the current setting of [Resolution](#) setting, the camera uses the maximum possible value.

Parameter	Partial Scan Auto Center
On	Automatically configure Partial Scan Offset X/Y so that the center area of the sensor is read out
True	
Off	Control Partial Scan Offset X/Y manually
False	
USB3 Vision: GenICam	OffsetAutoCenter
Type	Boolean
Video4Linux2	ROI Auto Center
VCD Property	VCDID_PartialScanOffset \VCDElement_PartialScanAutoCenter





## 4.1.6 Image Flipping

The DMK 37AUX252 camera allows flipping of the image data horizontally, vertically, or both. The *Flip Horizontal* and *Flip Vertical* parameters can be used to control this sensor feature.

Parameter	Flip Horizontal
True	Image data is flipped horizontally
False	Image data is not flipped horizontally
USB3 Vision: GenICam	ReverseX
Type	Boolean
Video4Linux2	Flip Horizontal
VCD Property	VCDID_FlipHorizontal\VCDElement_Value

Parameter	Flip Vertical
True	Image data is flipped vertically
False	Image data is not flipped vertically
USB3 Vision: GenICam	ReverseY
Type	Boolean
Video4Linux2	Flip Vertical
VCD Property	VCDID_FlipVertical\VCDElement_Value

## 4.2 Image Sensor Control

### 4.2.1 Exposure Time

The *Exposure Time* parameter defines the time the camera opens its (electronic) shutter when it is taking an image.

Parameter	Exposure Time
Minimum	1 $\mu$ s
Maximum	4 s
Default	auto
USB3 Vision: GenICam	ExposureTime
Type	Float
Video4Linux2	Exposure Time (us)
VCD Property	VCDID_Exposure\VCDElement_Value



## 4.2.2 Gain

The *Gain* parameter defines the amplification that is applied to the image at sensor level.

Parameter	Gain
Minimum	0 dB
Maximum	48 dB
Default	auto
USB3 Vision: GenICam	Gain
Type	Float
Video4Linux2	Gain (db/100)
VCD Property	VCDID_Gain\VCDElement_Value

## 4.2.3 Black Level

The *Black Level* parameter defines the lowest possibly intensity value of the image sensor.

Parameter	Black Level
Minimum	0
Maximum	4095
Default	240
USB3 Vision: GenICam	BlackLevel
Type	Float
Video4Linux2	Brightness
VCD Property	VCDID_Brightness\VCDElement_Value

## 4.3 Automatic Exposure and Gain Control

The DMK 37AUX252 camera can automatically control gain and exposure time. These automatic functions are enabled by default.

In order to optimize image parameters, a region of interest can be specified for automatic functions. Specifying a region of interest enables fine-grained control over the image area for which the image parameters are optimized. A selection of pre-defined area presets is available, but the user can also specify the coordinates of a custom rectangle.

In certain situations, it is desirable to limit the range of the auto-controlled parameters. For example, one might want to avoid high gain settings in order to keep noise levels low.



Other applications require limiting the maximum exposure time so that movements do not get blurred. Therefore, the ranges of the gain and exposure parameter can be limited.

If both auto exposure and auto gain are active, the camera tries to lower the gain value in order to reduce noise and improve the image quality.

## 4.3.1 Auto Exposure

Parameter	Auto Exposure
Continuous	Enable Auto Exposure
True	
Off	Disable Auto Exposure
False	
USB3 Vision: GenICam	ExposureAuto
Type	Enumeration
Video4Linux2	Auto Shutter
VCD Property	VCDID_Exposure\VCDElement_Auto

## 4.3.2 Auto Gain

Parameter	Auto Gain
Continuous	Enable Auto Gain
True	
Off	Disable Auto Gain
False	
USB3 Vision: GenICam	GainAuto
Type	Enumeration
Video4Linux2	Auto Gain
VCD Property	VCDID_Gain\VCDElement_Auto

## 4.3.3 Auto Reference Value

The *Auto Reference Value* parameter specifies the target brightness for both auto exposure and auto gain.



Parameter	Auto Reference Value
Minimum	0
Maximum	255
Default	128
USB3 Vision: GenICam	ExposureAutoReference
Type	Integer
Video4Linux2	ExposureAutoReference
VCD Property	VCDID_Exposure\VCDElement_AutoReference

### 4.3.4 Highlight Reduction

Enabling *Highlight Reduction* lets the auto exposure and auto gain functions reduce overexposed areas in the output image. This feature is particularly useful when using 10/12/16-bit output images and a tone mapping algorithm in post-processing when using higher bit depths as the dark areas still contain a lot of useful information.

Parameter	Highlight Reduction
True	Try to reduce overexposed areas
False	Ignore overexposed areas and focus on matching the image brightness to the selected <a href="#">Auto Reference Value</a> .
USB3 Vision: GenICam	ExposureAutoHighlightReduction
Type	Boolean
Video4Linux2	Highlight Reduction
VCD Property	VCDID_HighlightReduction\VCDElement_Value

### 4.3.5 Auto Exposure Limits

The *Auto Exposure Lower Limit* parameter determines the minimum possible value that can be set by the auto exposure algorithm.

Parameter	Auto Exposure Lower Limit
Minimum	1 $\mu$ s
Maximum	1 s
USB3 Vision: GenICam	ExposureAutoLowerLimit
Type	Float
Video4Linux2	Exposure Auto Lower Limit



The *Auto Exposure Upper Limit* parameter determines the maximum possible value that can be set by the auto exposure algorithm.

Parameter	Auto Exposure Upper Limit
Minimum	1 $\mu$ s
Maximum	1 s
USB3 Vision: GenICam	ExposureAutoUpperLimit
Type	Float
Video4Linux2	Exposure Auto Upper Limit
VCD Property	VCDID_Exposure\VCDElement_AutoMaxValue

If the *Auto Exposure Upper Limit Auto* parameter is enabled, the value of *Auto Exposure Upper Limit* is automatically kept at the maximum possible value for the current frame rate.

Parameter	Auto Exposure Upper Limit Auto
On	Select <i>Auto Exposure Upper Limit</i> automatically
Off	Let the user control <i>Auto Exposure Upper Limit</i>
USB3 Vision: GenICam	ExposureAutoUpperLimitAuto
Type	Enumeration
Video4Linux2	Exposure Auto Upper Limit Auto
VCD Property	VCDID_Exposure\VCDElement_AutoMaxValueAuto

### 4.3.6 Auto Gain Limits

The *Auto Gain Lower Limit* parameter determines the minimum possible value that can be set by the auto gain algorithm.

Parameter	Auto Gain Lower Limit
Minimum	0 dB
Maximum	48 dB
USB3 Vision: GenICam	GainAutoLowerLimit
Type	Float
Video4Linux2	Gain Auto Lower Limit

The *Auto Gain Upper Limit* parameter determines the maximum possible value that can be set by the auto gain algorithm.



Parameter	Auto Gain Upper Limit
Minimum	0 dB
Maximum	48 dB
USB3 Vision: GenICam	GainAutoUpperLimit
Type	Float
Video4Linux2	Gain Auto Upper Limit

## 4.4 Trigger

The trigger mode can be used to take images at very specific points in time which are specified by an electrical signal connected to the TRIGGER\_IN pin of the I/O connector of the camera.

### 4.4.1 Trigger Mode

The *Trigger Mode* parameter enables the trigger mode.

Parameter	Trigger Mode
On	Enable Trigger Mode
True	
Off	Disable Trigger Mode
False	
USB3 Vision: GenICam	TriggerMode
Type	Enumeration
Video4Linux2	Trigger Mode
VCD Property	VCDID_Trigger\VCDElement_Value

### 4.4.2 Trigger Polarity

The *Trigger Polarity* parameter controls whether a trigger event is accepted on the rising or falling edge of the signal connected to the TRIGGER\_IN line.



Parameter	Trigger Polarity
RisingEdge	Accept rising edge as trigger signal
True	
FallingEdge	Accept falling edge as trigger signal
False	
USB3 Vision: GenICam	TriggerActivation
Type	Enumeration
Video4Linux2	Trigger Polarity
VCD Property	VCDID_Trigger\VCDElement_Polarity

### 4.4.3 Software Trigger

The *Software Trigger* function can be used to simulate a trigger pulse, in turn causing one image to be exposed and delivered to the host computer.

Parameter	Software Trigger
Execute	Simulate one trigger pulse
USB3 Vision: GenICam	TriggerSoftware
Type	Command
Video4Linux2	Software Trigger
VCD Property	VCDID_Trigger\VCDElement_SoftwareTrigger

### 4.4.4 Trigger Exposure Mode

The *Trigger Exposure Mode* parameter sets the way in which the exposure time is controlled in trigger mode. By default, the exposure time is controlled through the [Exposure Time](#) parameter. The exposure time can also be controlled by the time the TRIGGER\_IN line is kept in active state.



Parameter	Trigger Exposure Mode
FrameStart	The exposure time is controlled by the <a href="#">Exposure Time</a> parameter
Timed	
ExposureActive	The exposure time is controlled by the pulse length on the TRIGGER_IN pin
Trigger Width	
USB3 Vision: GenICam	TriggerSelector
Type	Enumeration
Video4Linux2	Trigger Exposure Mode
VCD Property	VCDID_Trigger\VCDElement_TriggerExposureMode

#### 4.4.5 IMX Low-Latency Mode

The *IMX Low-Latency Mode* parameter controls whether the sensor operates in low-latency trigger mode.

Parameter	IMX Low-Latency Mode
True	Delay between trigger input and start of exposure is exactly as configured through the <i>Trigger Delay</i> feature
False	Delay between trigger input and start of exposure is the time configured by the <i>Trigger Delay</i> feature in addition to a random delay depending on resolution, frame rate, and timing relative to the sensor's internal state
USB3 Vision: GenICam	IMXLowLatencyTriggerMode
Type	Boolean
VCD Property	VCDID_Trigger\VCDElement_IMXLowLatencyMode

**Important:** If *IMX Low-Latency Mode* is enabled, *Trigger Overlap* is not allowed and is thereby forced to `Off`.

#### 4.4.6 Trigger Overlap

The *Trigger Overlap* feature gives information on when a new trigger pulse is accepted in the trigger -> exposure -> readout sequence.





Parameter	Trigger Overlap
Off	The next trigger pulse is only accepted once the previous frame has been read out from the sensor
Readout	The next trigger pulse is accepted during readout as long as the remaining readout time is shorter than the exposure time
USB3 Vision: GenICam	TriggerOverlap
Type	Enumeration
VCD Property	VCDID_Trigger\VCDElement_TriggerOverlap

## 4.4.7 Trigger Delay

The *Trigger Delay* parameter specifies a time for which the camera waits between receiving a trigger signal and starting the exposure of an image. Simulated trigger pulses generated through the *Software Trigger* function are not delayed by this parameter.

Parameter	Trigger Delay
Minimum	0 s
Maximum	0.1 s
USB3 Vision: GenICam	TriggerDelay
Type	Float
Video4Linux2	Trigger Delay
VCD Property	VCDID_Trigger\VCDElement_TriggerDelay

## 4.5 Digital I/O

The 37U series has one digital input and one digital output. The digital input can be used as a [Trigger](#) input but the current status can also be examined directly.

The digital output can be configured as a [Strobe](#) output to signal the exact moment when the image sensor is sensitive to light so that external light sources can be synchronized to its operation cycle.

### 4.5.1 General Purpose Input

The *General Purpose Input* parameter allows the current status of the TRIGGER\_IN pin.



Parameter	General Purpose Input
True	TRIGGER_IN line status is low
1	
False	TRIGGER_IN line status is high
0	
USB3 Vision: GenICam	GPIIn
Type	Boolean
Video4Linux2	GPIN
VCD Property	VCDID_GPIO\VCDElement_GPIORead VCDID_GPIO\VCDElement_GPIOIn

## 4.5.2 General Purpose Output

The *General Purpose Output* parameter controls the status of the STROBE\_OUT pin.

Parameter	General Purpose Output
True	Drive the STROBE_OUT line high
1	
False	Drive the STROBE_OUT line low
0	
USB3 Vision: GenICam	GPOut
Type	Boolean
Video4Linux2	GPOUT
VCD Property	VCDID_GPIO\VCDElement_GPIOWrite VCDID_GPIO\VCDElement_GPIOOut

## 4.6 Strobe

The strobe function controls the automatic generation of output pulses on the STROBE\_OUT pin which is synchronized to the image sensor's exposure time.

### 4.6.1 Strobe Enable

The *Strobe Enable* parameter enables the automatic generation of strobe pulses.



Parameter	Strobe Enable
On	Strobe enabled
True	
Off	Strobe disabled
False	
USB3 Vision: GenICam	StrobeEnable
Type	Enumeration
Video4Linux2	Strobe Enable
VCD Property	VCDID_Strobe\VCDElement_Value

## 4.6.2 Strobe Polarity

The *Strobe Polarity* parameter can be used to invert the strobe pulse output.

Parameter	Strobe Polarity
ActiveHigh	The STROBE_OUT pin is logically high during the exposure time
True	
ActiveLow	The STROBE_OUT pin is logically low during the exposure time
False	
USB3 Vision: GenICam	StrobePolarity
Type	Enumeration
Video4Linux2	Strobe Polarity
VCD Property	VCDID_Strobe\VCDElement_StrobePolarity

## 4.6.3 Strobe Operation

The *Strobe Operation* parameter specifies how the length of the strobe pulses are controlled.



Parameter	Strobe Operation
Exposure	Output pulse duration is equal to the current exposure time
True	
FixedDuration	Output pulse duration is specified by <i>Strobe Duration</i>
False	
USB3 Vision: GenICam	StrobeOperation
Type	Enumeration
Video4Linux2	Strobe Exposure
VCD Property	VCDID_Strobe\VCDElement_StrobeMode

#### 4.6.4 Strobe Duration

The *Strobe Duration* parameter controls the length of the strobe pulses if *Strobe Operation* is set to use the fixed duration mode.

Parameter	Strobe Duration
Minimum	0 $\mu$ s
Maximum	32767 $\mu$ s
USB3 Vision: GenICam	StrobeDuration
Type	Integer
Video4Linux2	Strobe Duration
VCD Property	VCDID_Strobe\VCDElement_StrobeDuration

#### 4.6.5 Strobe Delay

The *Strobe Delay* parameter can be used to add a small delay between the start of exposure and the strobe output pulse.

Parameter	Strobe Delay
Minimum	0 $\mu$ s
Maximum	32767 $\mu$ s
USB3 Vision: GenICam	StrobeDelay
Type	Integer
Video4Linux2	Strobe Delay
VCD Property	VCDID_Strobe\VCDElement_StrobeDelay



## 4.7 Region of Interest for Auto Functions

The 37U series cameras allow for the setting of a region of interest that is used while controlling the [Auto Exposure](#), [Auto Gain](#) and Auto White Balance functions.

### 4.7.1 Auto Functions ROI Enable

The *Auto Functions ROI Enable* parameter allows for the use of a region of interest for auto functions.

Parameter	Auto Functions ROI Enable
True	Auto functions only take a specified part of the image into account
False	Auto functions look at the whole image
USB3 Vision: GenICam	AutoFunctionsROIEnable
Type	Boolean
Video4Linux2	Auto Functions ROI Enable
VCD Property	VCDID_AutoRoi\VCDElement_Value

### 4.7.2 Auto Functions ROI Preset

The *Auto Functions ROI Preset* parameter lets the user select from a list of ROI presets.

Parameter	Auto Functions ROI Preset
Center 50%	Select a rectangular area in the center of the output image
USB3 Vision: GenICam	AutoFunctionsROI_Preset
Type	Enumeration
Video4Linux2	Auto Functions ROI Preset
VCD Property	VCDID_AutoRoi\VCDElement_AutoRoiPreset

## 4.8 User Sets

The 37U series cameras can store their complete configuration into built-in non-volatile memory. The camera configuration can be saved into and restored from one of two available memory slots upon user's request. Additionally, the camera can be configured to load one of the user's camera configurations at startup.

### 4.8.1 User Set Selector

The *User Set Selector* parameter selects the memory slot on which consecutive load and save commands are executed.



Parameter	User Set Selector
UserSet1	First of the two memory slots for user configurations
UserSet2	Second of the two memory slots for user configurations
Default	A special memory slot that always contains the camera's factory default configuration. It cannot be overwritten
USB3 Vision: GenICam	UserSetSelector
Type	Enumeration

## 4.8.2 Load User Set

By using the *Load User Set* command, the user can restore the camera configuration from the memory slot selected by *User Set Selector*.

Parameter	Load User Set
Execute	Restore the camera configuration from the memory slot specified by <i>User Set Selector</i>
USB3 Vision: GenICam	UserSetLoad
Type	Command

## 4.8.3 Save User Set

By using the *Save User Set* command, the user can save the camera configuration into the memory slot selected by *User Set Selector*.

Parameter	Save User Set
Execute	Save the current camera configuration into the memory slot specified by <i>User Set Selector</i>
USB3 Vision: GenICam	UserSetSave
Type	Command

## 4.8.4 Default User Set

The *Default User Set* parameter controls the camera's startup behavior. It selects which memory slot is used for device initialization when the camera is powered up.



Parameter	Default User Set
UserSet1	Load configuration from the first memory slot
UserSet2	Load configuration from the second memory slot
Default	Load factory default configuration
USB3 Vision: GenICam	UserSetDefault
Type	Enumeration

## 4.9 Multi-Frame Output Mode

The 37U series cameras support cycling the exposure time through pre-programmed values from frame to frame in order to form a frame set. In post-processing, sets of frames captured with different exposure times can be used to create images with higher dynamic range than those from single exposure.

The camera can be configured to use 2 or 4 different exposure times.

If required, different gain values can be selected for use along with the configured exposure times.

### 4.9.1 Multi-Frame Output Mode Enable

The *Multi-Frame Output Mode Enable* parameter activates the multi-frame output mode.

Parameter	Multi-Frame Output Mode Enable
True	Cycle through the exposure times specified by Multi-Frame Output Mode Exposure Time
False	Use the exposure time defined by Exposure Time for all frames
USB3 Vision: GenICam	MultiFrameSetOutputModeEnable
Type	Boolean
VCD Property	VCDID_MultiFrameOutputMode \VCDElement_Value

### 4.9.2 Multi-Frame Output Mode Frame Count

The *Multi-Frame Output Mode Frame Count* parameter defines the number of frames in a frame set.



Parameter	Multi-Frame Output Mode Frame Count
2 Frames	Use two different exposure times
4 Frames	Use four different exposure times
USB3 Vision: GenICam	MultiFrameSetOutputModeFrameCount
Type	Enumeration
VCD Property	VCDID_MultiFrameOutputMode \VCDElement_MultiFrameCount

### 4.9.3 Multi-Frame Output Mode Exposure Time

The *Multi-Frame Output Mode Exposure Time* parameters control the different exposure times in a frame set.

Parameter	Multi-Frame Output Mode Exposure Time
Minimum	1 $\mu$ s
Maximum	4000000 $\mu$ s
USB3 Vision: GenICam	MultiFrameSetOutputModeExposureTime0 MultiFrameSetOutputModeExposureTime1 MultiFrameSetOutputModeExposureTime2 MultiFrameSetOutputModeExposureTime3
Type	Float
VCD Property	VCDID_MultiFrameOutputMode \VCDElement_MultiFrameExposure0 \VCDElement_MultiFrameExposure1 \VCDElement_MultiFrameExposure2 \VCDElement_MultiFrameExposure3

### 4.9.4 Multi-Frame Output Mode Custom Gain

The *Multi-Frame Output Mode Custom Gain* parameter allows specifying different gain values for each frame in a frame set.

Parameter	Multi-Frame Output Mode Custom Gain
True	Cycle through the gain values specified by Multi-Frame Output Mode Gain
False	Use the gain value defined by Gain
USB3 Vision: GenICam	MultiFrameSetOutputModeCustomGain
Type	Boolean
VCD Property	VCDID_MultiFrameOutputMode \VCDElement_MultiFrameCustomGainEnable





## 4.9.5 Multi-Frame Output Mode Gain

The *Multi-Frame Output Mode Gain* parameters controls the gain values used to capture the images of the frame set.

Parameter	Multi-Frame Output Mode Gain
Minimum	0 dB
Maximum	48 dB
USB3 Vision: GenICam	MultiFrameSetOutputModeGain0 MultiFrameSetOutputModeGain1 MultiFrameSetOutputModeGain2 MultiFrameSetOutputModeGain3
Type	Float
VCD Property	VCDID_MultiFrameOutputMode \VCDElement_MultiFrameGain0 \VCDElement_MultiFrameGain1 \VCDElement_MultiFrameGain2 \VCDElement_MultiFrameGain3

## 4.10 Timestamp Control

37U series cameras run an internal timestamp clock. The clock starts at zero when the camera is powered up.

The source of the timestamp clock has a frequency tolerance of  $\pm 50$  ppm.

All image buffers sent by the camera have a timestamp attached to them.

### 4.10.1 Timestamp Latch

The *Timestamp Latch* command copies the current value of the camera's timestamp counter into the [Timestamp Latch Value](#) so that it can be read later.

Parameter	Timestamp Latch
Execute	Copies the current value of the camera's timestamp into <a href="#">Timestamp Latch Value</a> .
USB3 Vision: GenICam	TimestampLatch
Type	Command

### 4.10.2 Timestamp Latch Value

The *Timestamp Latch Value* feature contains the value of camera's timestamp counter at the time of the previous execution of the [Timestamp Latch](#) command.



Parameter	Timestamp Latch Value
USB3 Vision: GenICam	TimestampLatchValue
Type	Integer
Unit	μs

### 4.10.3 Timestamp Reset

The *Timestamp Reset* command resets the camera's timestamp counter to start from zero.

Parameter	Timestamp Reset
Execute	Resets the camera's timestamp counter.
USB3 Vision: GenICam	TimestampReset
Type	Command

## 4.11 Bandwidth Control

When using multiple 37U series devices connected to the same host controller, the data rate has to be considered to allow consistent operation.

To limit the bandwidth of a camera, set [Device Link Throughput Limit Mode](#) to `On`, and set [Device Link Throughput Limit](#) to the desired maximum data rate.

### 4.11.1 Device Link Throughput Limit Mode

The *Device Link Throughput Limit Mode* parameter enables or disables the effect of [Device Link Throughput Limit](#).

If set, the camera's internal frame rate is automatically reduced to fit into the available bandwidth.

Parameter	Device Link Throughput Limit Mode
Off	The bandwidth the device uses for streaming is unlimited.
On	The maximum bandwidth the device uses for streaming is defined by <a href="#">Device Link Throughput Limit</a> .
USB3 Vision: GenICam	DeviceLinkThroughputLimitMode
Type	Enumeration

### 4.11.2 Device Link Throughput Limit

The *Device Link Throughput Limit* parameter defines the maximum bandwidth used by the device to stream data.



[Device Link Throughput Limit Mode](#) must be set to `On` for *Device Link Throughput Limit* to have an effect.

Parameter	Device Link Throughput Limit
Minimum	1000000 Mbps
Maximum	400000000 Mbps
USB3 Vision: GenICam	<code>DeviceLinkThroughputLimit</code>
Type	Integer



## 5 Revision History

Date	Version	Description
2018/08/28		Initial release of this document
2019/07/02	Firmware 1069	Add support for User Sets
2023/07/19		Updated environmental section in quick facts chapter.
2024/11/13	Firmware 1732	Add DeviceLinkThroughputLimit feature



## DMK 37AUX252 Technical Reference Manual

All product and company names in this document may be trademarks and tradenames of their respective owners and are hereby acknowledged.

The Imaging Source Europe GmbH cannot and does not take any responsibility or liability for any information contained in this document. The source code presented in this document is exclusively used for didactic purposes. The Imaging Source does not assume any kind of warranty expressed or implied, resulting from the use of the content of this document or the source code.

The Imaging Source Company reserves the right to make changes in specifications, function or design at any time and without prior notice.

Last update: April 2025

© 2025 The Imaging Source

All rights reserved. Reprint, also in parts, only allowed with permission of The Imaging Source Europe GmbH.

All weights and dimensions are approximate. Unless otherwise specified, the lenses shown in the context of cameras are not shipped with these cameras.

### **Headquarters:**

*The Imaging Source Europe GmbH  
Überseetor 18, D-28217 Bremen, Germany  
Phone: +49 421 33591-0*

### **North & South America:**

*The Imaging Source, LLC  
4600 Park Road, Suite 470, Charlotte, NC 28209, United States  
Phone: +1 877-462-4772*

### **Asia Pacific:**

*The Imaging Source Asia Co., Ltd.  
3F., No. 43-7/8, Zhongxing Road  
Xizhi District, New Taipei City 221012, Taiwan  
Phone: +886 2-2792-3153*

[www.theimaging-source.com](http://www.theimaging-source.com)